



# **MOUNTING INSTRUCTION**

---

# **SECTIONAL DOOR OPERATORS**

---

*SD / SW*



## 1. CONTENTS

1. Contents.....	3
2. General instructions.....	3
3. Safety-related regulations .....	4
4. Safety instructions .....	4
5. Mounting .....	5
6. Initial operation .....	6
7. Technical data .....	11
8. Drawings .....	12
9. Maintenance.....	13
10. Transport, Storage, Disposal .....	13
11. Service, Spare parts, Accessories .....	13
12. Declaration of Incorporation .....	14
13. Annex.....	15

## 2. GENERAL INSTRUCTIONS

### 2.1 Original operating instructions

This manual is the original manual.

- Copyright protection: any reproduction is permitted only with approval of the manufacturer.
- Subject to alterations in the interest of technical progress.
- All dimensions given in mm. The diagrams in this manual are not to scale.

### 2.2 Intended use

The operator series SD, SW and SDA are intended for driving loads that do not need to be secured against falling, such as: weight counterbalanced sectional doors.

For other applications of the operators, the manufacturer must be consulted.

### 2.3 Warranty

The function and safety of the equipment is only guaranteed if the warning and safety instructions included in these operating instructions are adhered to.

The manufacturer is not liable for injury to persons or damage to property if these occur as a result of the warnings and safety advice being disregarded.

The CE declaration and the warranty will void if components are changed.

Only original spare parts and by the manufacturer approved accessories shall be used. These parts are used to maintain the quality and safety of the machine.

Changes are only permitted after consultation with the manufacturer.

### 2.4 Target group

Only qualified and trained specialists are permitted to mount the operator and perform mechanical maintenance.

Only qualified and trained electricians may connect the operator and carry out the electrical maintenance.

Qualified and trained people have knowledge of general and specific safety and accident prevention regulations, the relevant regulations and standards, training in the use and maintenance of adequate safety equipment, as well as the ability to recognize hazards associated with their work.

### 2.5 Key to symbols



#### DANGER !

Indicates a hazard with a high level of risk which, if not avoided, will result in death or serious injury.



#### WARNING !

Indicates a hazard with a medium level of risk which, if not avoided, could result in death or serious injury.



#### CAUTION !

Indicates a hazard with a low level of risk which, if not avoided, could result in minor or moderate injury.

#### NOTICE !

Indicates an imminent danger of damage or destruction.

#### INFORMATION !

Reference to separate documents which must be complied with.

### 3. SAFETY-RELATED REGULATIONS

For connecting, programming and servicing, the following regulations must be observed (the list is not exhaustive)!

Construction product standards:

- EN 13241-1
- EN 12445
- EN 12453
- EN 12635
- EN 12978

Electromagnetic compatibility (EMC):

- EN 55014-1
- EN 61000-3-2
- EN 61000-3-3
- EN 61000-6-2
- EN 61000-6-3

Machinery Directive:

- EN 60204-1
- EN 12100-1

Local protective regulations must be complied with.

### 4 SAFETY INSTRUCTIONS



#### **DANGER !**

Failure to observe the instructions in this document can result in mortal danger!



#### **DANGER !**

Risk of death by electric shock!

- When installing the operator, when opening housings and work on electrical equipment, the operator has to be disconnected from the power.
- Observe the local safety regulations.

#### **NOTICE !**

To avoid damage to the operator and at the door, the drive must be mounted only if :

- the drive is undamaged,
- the ambient temperature is  $-20^{\circ}\text{C}$  to  $+60^{\circ}\text{C}$ ,
- the installation site altitude does not exceed 1,000 m above sea level.
- The use of the operator, as well as the standard cable is only allowed indoors.
- For outdoor installation must be consulted with the manufacturer.



#### **WARNING !**

- Make sure that children can not access the door control or the hand-held transmitter.
- Ensure, before moving the door, that no persons or objects within range of the door.
- Test all existing emergency command devices.
- Pay attention to possible crushing and shearing points on the door system.
- Never reach into a running gate, into the guide rail or moving parts.

#### **INFORMATION !**

For drives with fixed connection a main switch with appropriate building main fuse must be provided.



#### **WARNING !**

Before installation, ensure that:

- the operator is installed with the intended covers or guards,
- all seals are correctly and
- all glands and screws are tightened correctly.

## 5. MOUNTING

### 5.1 Preparation

- Check that the delivery is complete.
- Check if all accessories for your installation situation are present (e.g. console).
- Check if the system has a suitable mains connection and a mains switch.
- Remove all unnecessary components from the door
- Remove all devices, which are not required after installation of the drive system.
- Before installation, ensure that the operator is not blocked.
- Before installation, ensure that the operator has been newly prepared after a lengthy storage period.
- Before installation, ensure that no other sources of danger are present.
- Before installation, ensure that the installation site has been cordoned off over a wide area.



#### **DANGER !**

All components must be designed in relation to the construction and the ground for the loads during tripping of the safety catch device.

### 5.2 Mounting of the Operator

- Install the torque bracket

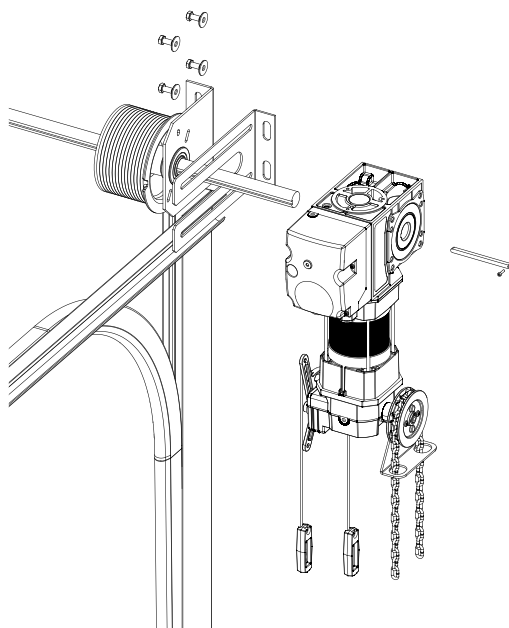

- Insert the feather key into the shaft
- The shaft end is greased before fitting the drive
- When using collars, slide the collar onto the shaft
- Secure the feather key against sliding

Mounting operator in inverted position:

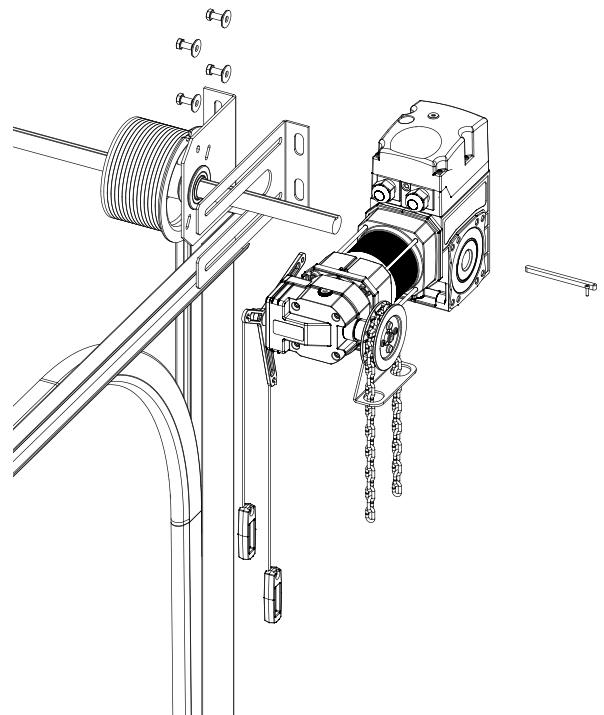

#### **NOTICE !**

- To avoid damage to the operator and to the door, the operator must be mounted with torque support bracket so that it is vibration damped.
- When mounting the operator do not carry or pull at the cable.



#### **DANGER !**

With a continuous shaft groove the feather key has to be secured against moving.



**CAUTION !**

For operators with weights greater than 20 kg additional aids shall be used, such as hooks or ropes for securing and lifting. On the drives corresponding eyes are provided.

**INFORMATION !**

The relevant instructions for the door must be observed when fitting the operator to the door.

**6. INITIAL OPERATION**

Power-operated doors shall be audited at least annually by a trained person, before first use and as required (with written proof).

The operator of the door system, shall be trained after initial operation.

Before installation, ensure that the direction of rotation of the gear motor is correct, and all protective devices are active.

**6.1 Connection to the control unit**

The operator is factory wired to the control unit. If this is not the case, proceed as follows:

- Remove the cover from the operator.
- Run the cable gland of the cable into the corresponding fitting.
- Connect the motor cable to the plug, the plug is polarized.
- Connect the limit switch:  
AWG: connect plug  
Mechanical limit switch: connect according to diagram
- Attach the cover back on the operator.

**NOTICE !**

When mounting the motor cables to ensure that the individual wires are inserted deep enough and the screws are tightened so that a firm connection is made. This connection can be checked by pulling the cables.

**NOTICE !**

To avoid damage to the drive, the following points must be observed:

- The types of cable and their diameters must be selected according to current regulations.
- The nominal currents and the type of connection must correspond to those on the motor type plate.
- The drive details must agree with the connected loads.



**DANGER !**

Danger of fatal electric shock!

Before commencing cabling works, you MUST disconnect the drive system from the mains supply. Ensure that the electricity supply remains disconnected throughout the cabling works.

**Connection**

Connection to cable set for mechanical limit switches:

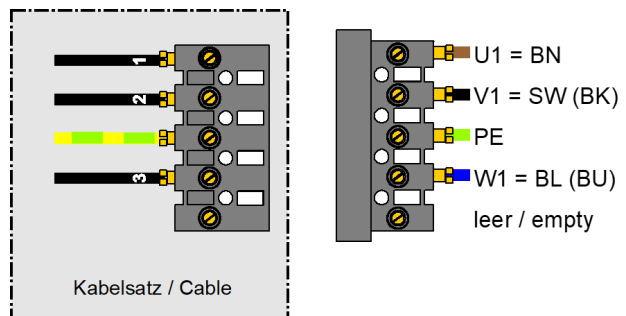

Connection to cable set for electronic limit switches:

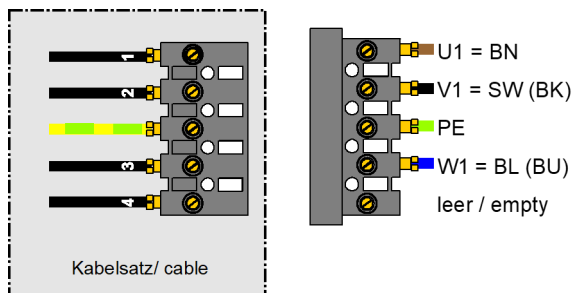

## 6.2 Mechanical limit switch

Cam (from outside in)	ME 4 (4 cams)
RED	Safety limit switch open
GREEN	Limit switch open
GREEN	Limit switch close
RED	Safety limit switch close

Cam (from outside in)	ME 6 (6 cams)
RED	Safety limit switch open
GREEN	Limit switch open
GREEN	Add. Limit switch 1
WHITE	Limit switch close
RED	Safety limit switch close
WHITE	Add. Limit switch 2

## 6.3 Connection

Terminal 2 is only available in version ME6. The safety switch of the emergency hand operation system and the thermo overload protection of the operator are connected in series with the safety limit switches.

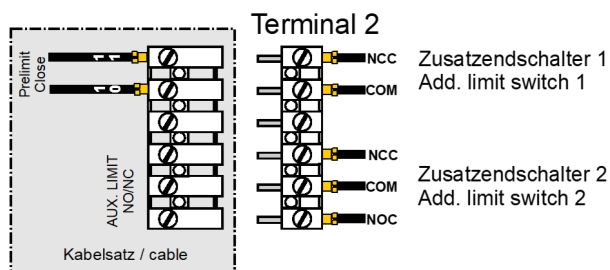
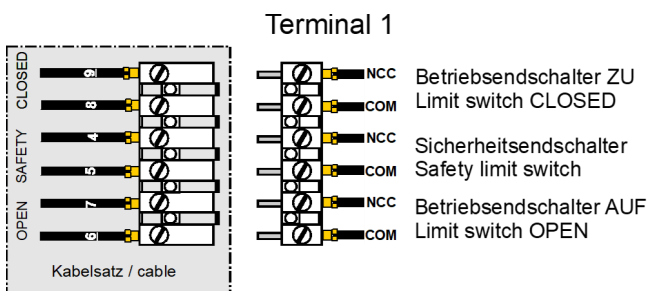

## 6.4 Setting the end positions: mechanical limit switch

For the adjustment of the cam an Allen key size 2.5 is required (included with the drive). The cam is fixed on the correct switch position using the locking screw after positioning (rough setting). Fine adjustment is possible via the precision set screw.

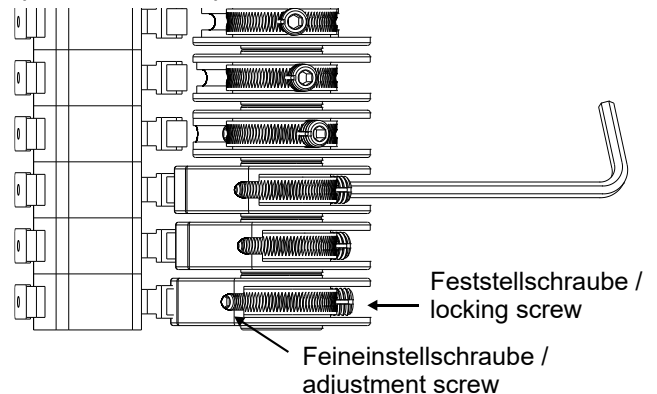

To set the limit switch, the operator must be ready for operation, completely mechanically fitted and electrically connected.

Before the first activation of the operator the door should be in a center position to ensure there is sufficient travel in both directions when starting.

On actuating the button OPEN, the door must open. Otherwise the two phases L1 and L2 have to be exchanged. To do this, control and drive must be disconnected from the main supply!

### Setting the CLOSED end position

- Bring the door in the CLOSED end position.
- Set the cam so that the CLOSED limit switch is actuated.
- Tighten the locking screw.
- The Safety limit switch CLOSED must be set so that it switches immediately when the limit switch CLOSED is passed over.
- Adjust the safety limit switch CLOSED.

### Setting the OPEN end position

- Bring the door in the OPEN end position.
- Set the cam so that the OPEN limit switch is actuated.
- Tighten the locking screw.
- The Safety limit switch OPEN must be set so that it switches immediately when the limit switch OPEN is passed over.
- Adjust the safety limit switch OPEN.

### Additional limit switches:

- Bring the door to the desired position from the desired direction (e.g. partial open position from the position CLOSED).
- Set the switch cam so that the additional limit switch is actuated.
- Tighten the locking screw.

### Correct the end positions

With the fine adjustment screw a readjustment of the respective end position is possible.

### Check of end positions

Check if the end positions are set correctly and if the operator stops in the corresponding end position.

### 6.5 Connection of the electronic limit switch

The electronic (digital) limit switch is an absolute value encoder.

It is connected via an RS485 interface to the control unit. The encoder has a 6-pin connector on the serial interface, which is connected to the control unit.

The safety switches of the operator are connected to the terminals 7 - 12. Unused terminals must be equipped with a wire bridge.

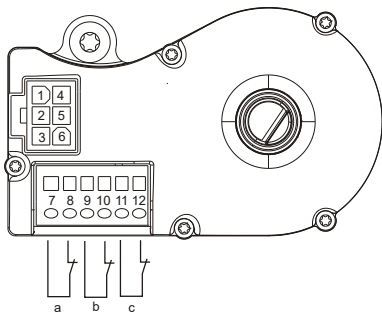

Pin	Assignment	Color
1	Safety chain in	Yellow
2	RS 485 B	Green
3	0 VDC	White
4	RS 485 A	Pink
5	Safety chain out	Grey
6	7 ... 18 VDC	Brown

### 6.6 Setting the end positions: electronic limit switch

Please refer to the control unit operating manual for instructions on setting the end positions.

### 6.7 Emergency operation

During maintenance works or in the case of an electrical fault, the door can be moved towards the OPEN or CLOSED positions with the help of the emergency operation equipment.



#### **DANGER !**

Serious injuries are possible due to uncontrolled door movement!

To avoid personal injury, a safety catch device must be mounted at the door (e.g. spring break device) if a operator with declutch system is used.



#### **DANGER !**

Serious injuries are possible due to uncontrolled door movement!

Before releasing the maintenance declutch system the door must be secured against falling.



#### **WARNING !**

Improper use may result in serious injury!

- Emergency operation must only be carried out when the motor is stationary.
- The system must be disconnected from the power supply during emergency operation.
- Emergency operation must only be carried out from a safe standing position.



### 6.8 Declutch system

The mounting position of the actuator with unlocking is preferably present in an inverted position (motor pointing downwards).

For mounting in an upright position, an additional cable guide is required!

The handles are for switching between motor and manual mode until.

1. Red handle - HAND (system coupled):  
Switching to manual mode.
2. Open or close the door
3. Green handle - MOTOR- (system decoupled)  
Switching to motor operation
4. The door can be operated again electrically

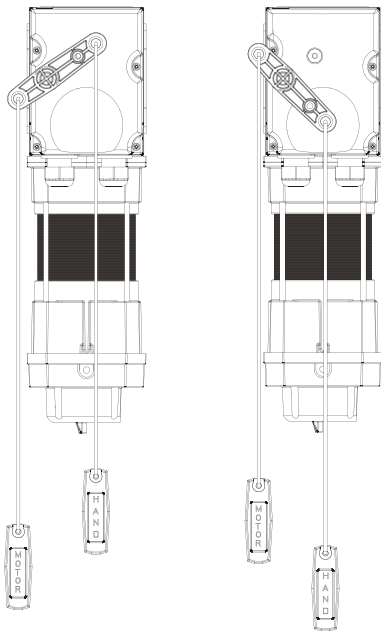

system decoupled  
(motor operation)

system coupled  
(manual operation)

### 6.9 Maintenance declutch system

For use as maintenance system, the release lever can be fixed with a screw in the position for motor operating (decoupled).

For the purpose of maintenance, the screw can be unscrewed and the drive can be disengaged. No actuation ropes are attached.

In addition, the drive will be equipped with a hand crank or hand chain system for manual operation.

### 6.10 Hand crank

A insertion aid at the housing of emergency crank handle facilitates the insertion of the crank.

1. Release the emergency hand crank from its fixing.
2. Insert the hand crank with slight pressure and a little turning into the operator as far as it will go.
3. A micro switch is actuated and interrupts the energy supply to the motor via the safety circuit in the control system.
4. Open or close the door using the hand crank.
5. If the crank is removed, the micro switch automatically releases the control system. The door can be operated electrically again.

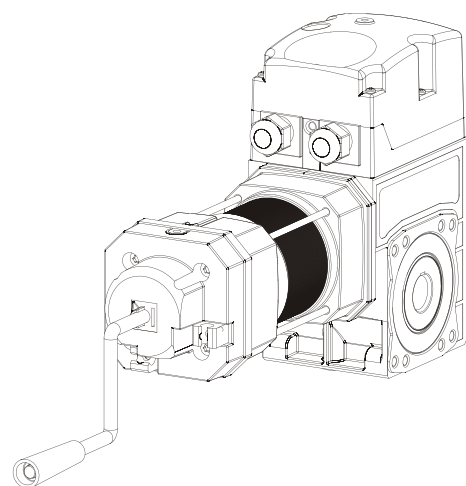
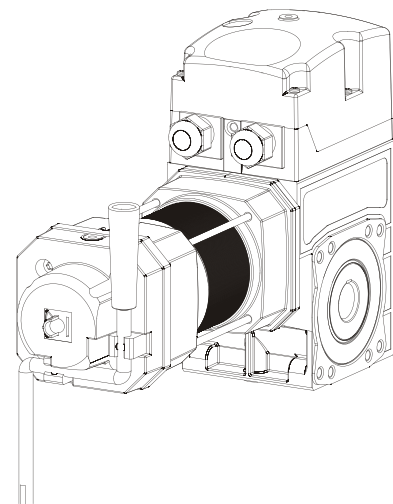

### 6.11 Hand chain

By pulling the release lever, the coiler shaft of the hand chain system is shifted and thus switches between motor- and manual operation.

When switching to manual mode a micro switch is actuated and interrupts the safety circuit. No motor operation is possible.

1. Red handle - HAND (system coupled):  
Switching to manual mode  
(the operating force is max. 390 N)
2. Open or close the door using the hand chain
3. Green handle - MOTOR- (system decoupled)  
Switching to motor operation  
(the operating force is max. 390 N)
4. The door can be operated again electrically

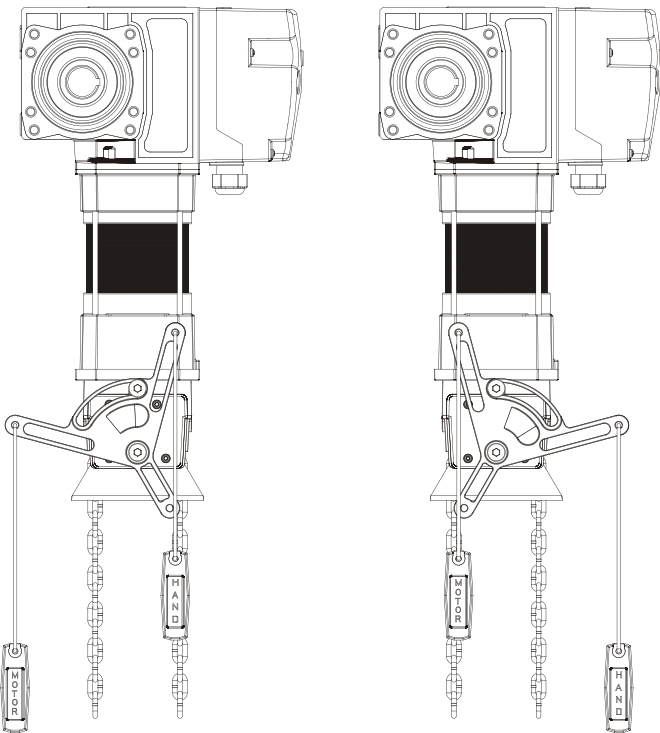

system decoupled  
(motor operation)

system coupled  
(manual operation)

### 6.12 Extending or shortening the chain

The coil is joined via one or two coupling links (marked by the color yellow).

It can be opened at the coupling link and can be extended with a piece of chain and another coupling link.

When shortening, the respective part is to be separated from the coil chain using a bolt cutter. The coupling links must be carefully bent together.

When making changes to the coil chain, make sure that the chain is not twisted when mounted.

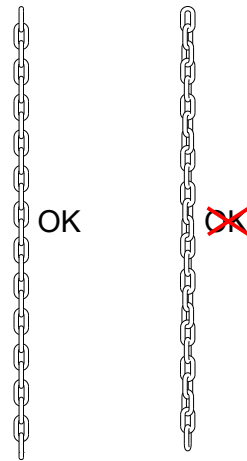

chain not  
twisted

chain twisted

### 6.13 Rotate the hand chain system

The emergency chain system can be rotated by 180° so that the coil wheel is on the other side.

To do this, the 4 fastening screws have to be unscrewed, the housing has to be rotated by 180° and then re-tightened (M=7Nm).

## 7. TECHNICAL DATA

Antriebstyp Operator Type	Anlauf- Drehmoment Starting Torque	Nenn- Drehmoment Nominal Torque	Abtriebsdrehzahl Output Speed	Haltemoment Holding Torque	Endschalterbereich <sup>1)</sup> Limit capacity	Hohlwellen Durchmesser <sup>2)</sup> Hollowshaft Diameter	Betriebsspannung (50Hz) Operating Voltage (50 Hz)	Motorleistung Motor Output	Motoreinschaltdauer Duty Cycle Motor	Nenn – Strom bei 230 / 400V Nominal Current at 230 / 400 V	Art der Notberatigung Type of manual operation	Schutzart Protection Category	Masse Mass
	M <sub>A</sub> [Nm]	M <sub>N</sub> [Nm]	n <sub>2</sub> [min <sup>-1</sup> ]	[Nm]	i <sub>stw</sub>	D [mm]	U [V]	P [kW]		I <sub>N</sub> [A]		IP	m [kg]
<b>SW-50.24</b>	50	40	24	> 600	15	25,4	1~230	0,18	LD	3,7	E/KU/ KS/KE	54	12,0
<b>SD-70.18</b>	70	55	18	> 600	15	25,4	3~230 3~400	0,37	MD HD	1,5 2,6	KU KS	54	12,0
<b>SD-90.30</b>	80	65	30	> 600	15	25,4	3~230 3~400	0,37	MD HD	1,5 2,6	E/KU/ KS/KE	54	12,0
<b>SD-100.24</b>	100	80	24	> 600	15	25,4	3~230 3~400	0,37	MD HD	1,5 2,6	E/KU/ KS/KE	54	12,0
<b>SD-120.30</b>	100	80	30	> 600	20	31	3~230 3~400	0,55	MD HD	2,45 3,0	E/KU/ KS/KE	54	12,0
<b>SD-130.24</b>	130	100	24	> 600	15	25,4	3~230 3~400	0,55	MD HD	2,0 3,5	E/KU/ KS/KE	54	12,0
<b>SD-140.18</b>	140	115	18	> 600	15	25,4	3~230 3~400	0,55	MD HD	2,0 3,5	E/KU/ KS/KE	54	12,0
	140	115	18	> 600	15	31,75	3~230 3~400	0,55	MD HD	2,0 3,5	E/KU/ KS/KE	54	12,0

<sup>1)</sup> Limit ratio 20:1 respectively 40:1 available on request

<sup>2)</sup> Keyway 6,35<sup>2</sup> mm (1/4") – different hollow-shaft-Ø on request

For door gate systems with more cycles than usual, a drive with duty cycle HD should be chosen.

## 8. TECHNICAL DRAWINGS

Version KU

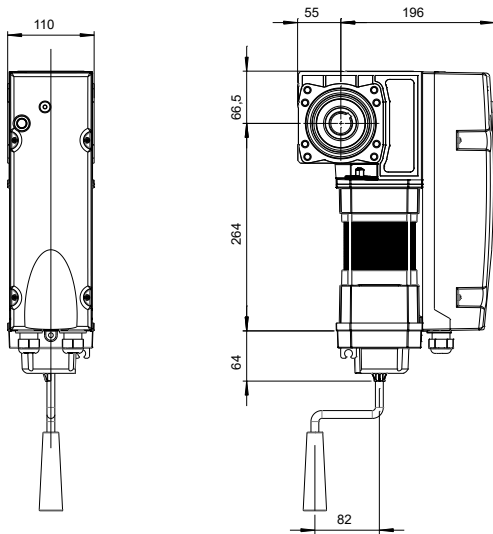

Version E

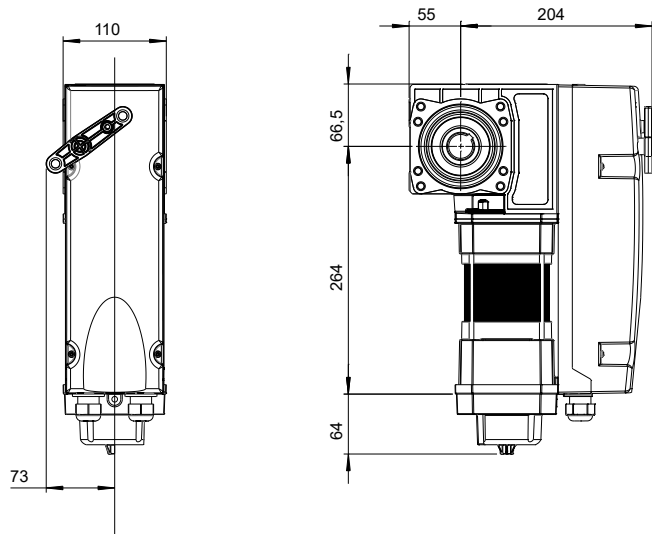

Version KE

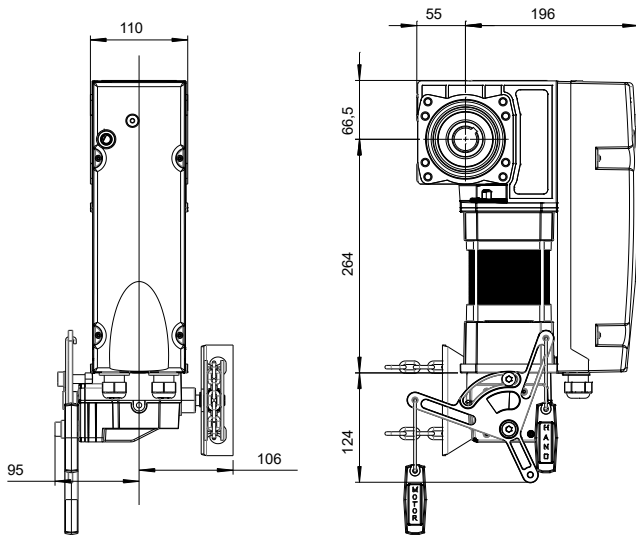

Version KS

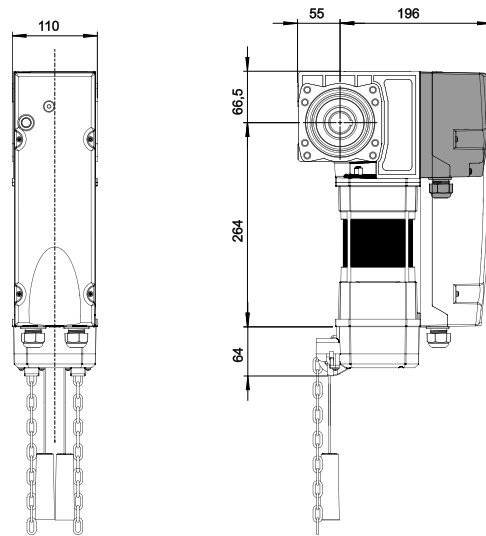

### Mounting points

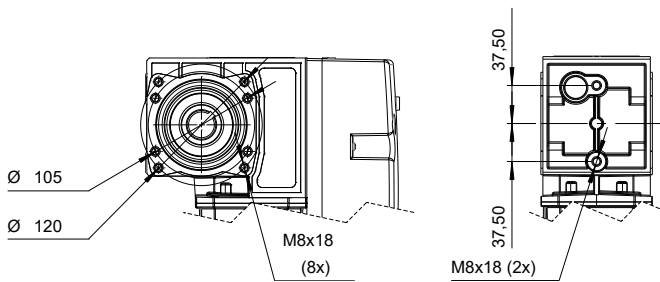

## 9. MAINTENANCE / ANNUAL INSPECTION



### DANGER !

Danger of fatal electric shock!

- For the maintenance of the operator, when opening the housings and work on the electrical equipment, the operator must be disconnected from the main power.



### DANGER !

Serious injuries are possible due to uncontrolled door movement!

Before releasing the maintenance declutch system the door must be secured against falling.

### NOTICE !

- Only original spare parts and approved accessories shall be used.
- Changes are only permitted after consultation with the manufacturer.

### INFORMATION !

- The maintenance of power-operated windows, doors and gates must be performed only by authorized persons who are familiar with the relevant maintenance and the national and local regulations.

### 9.1 Gear unit

The gear unit has lifetime lubrication and is maintenance-free. The hollow shaft must be kept rust-free. Check for noise and oil leakage.

### 9.2 Motor

The motor is maintenance free.

### 9.3 Fixtures

All fastening screws must be checked for tightness and proper condition.

### 9.4 Cabling

Check power cord and cables regularly for damage and insulation failure.

## 10. TRANSPORT, STORAGE, DISPOSAL

The drive has been fully assembled at the factory, ready wired, tested and packaged.

To avoid damage, transport and store the operator in the original packaging or an equivalent substitute.

For the disposal, the national regulations must be observed.

### INFORMATION !

Attention!

The gearbox contains oil. A proper disposal must be ensured.

## 11. SERVICE, SPARE PARTS, ACCESSORIES

Only original spare parts and approved accessories must be used. The use of non-original spare parts and accessories may affect the functionality and the safety of the system. For damages incurred thereby, any liability and warranty is excluded.

In the case of malfunctions which can not be fixed easily in person, please consult a specialist from the manufacturer of the door system or another specialist company.

## 12. DECLARATION OF INCORPORATION

We hereby declare that the products described below:

### **Sectional door operators of the model ranges SD, SW and SDA**

are in conformity with the essential requirements of the Machinery Directive 2006/42/EC.

In addition, the partly completed machinery is in conformity with

the Construction Products Regulation (EU) No 305/2011

the Electromagnetic Compatibility Directive 2014/30/EU

the Low Voltage Directive 2014/35/EU

The following standards were applied:

EN 60204-1

EN 12100-1

DIN EN 12453

DIN EN 12604

EN 61000-6-2

EN 61000-6-3

EN 60335-1

EN 60335-2-103

### **Manufacturer and technical documentation management**

Tornado Antriebstechnik GmbH  
Flohrstr. 33  
D-13507 Berlin

The relevant technical documentation is compiled in accordance with Annex VII(B) of the Machinery Directive 2006/42/EC. We undertake to transmit, in response to a reasoned request by the market surveillance authorities, this documentation in electronic form within a reasonable period of time.

The machinery is incomplete and must not be put into service until the machinery into which the partly completed machinery is to be incorporated has been declared in conformity with the provisions of the Machinery Directive 2006/42/EC.

### **Place, Date**

Berlin, 01.09.2019

### **Manufacturer's signature**

**Franck Poirier**



### **Sales Director/ authorized signatory**

### 13. ANNEX - STAR, DELTA CONNECTION

The operator in the standard version is suitable as three-phase motor for 230V/400V operation.

By rewiring it is possible to switch the operator from the factory star connection for 3 ~ 400V to the delta connection for 3 ~ 230V.

The winding ends have to be rewired as shown below:



**DANGER !**

Danger of fatal electric shock!

Before commencing cabling works, you **MUST** disconnect the drive system from the mains supply. Ensure that the electricity supply remains disconnected throughout the cabling works.

The nominal cross section of the wires in the terminal is max. 2.5 mm<sup>2</sup>.

After reconnecting, the rotation direction of the drive has to be confirmed.

**NOTICE !**

If the motor is wired to delta (3 ~ 230) ensure, that the control unit and the mains power supply are adapted to this voltage!

When reconnecting the motor cable, make sure that the individual lines are inserted deep enough into the connector and the screws are tightened properly (torque max. 0.5 Nm). The connection can be checked by gently pulling at the cable.

#### Star 3~400V

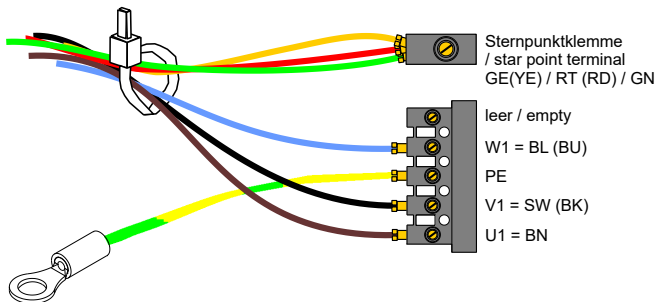

#### Delta 3~230V

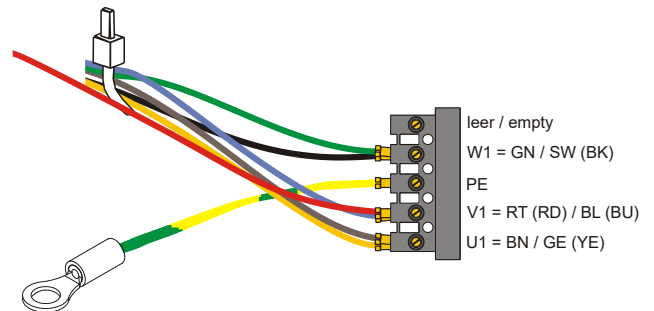

# PRODUCTS

- ▶ Rolling Shutter Operators
- ▶ Sectional Door Operators
- ▶ High-Speed Door Operators
- ▶ Chain Wheel Operators
  - ▶ Control Panels
- ▶ Safety Systems
- ▶ Accessories